FRONT SUSPENSION

CONTENTS

33209000202

GENERAL INFORMATION	2	ON-VEHICLE SERVICE	4
SERVICE SPECIFICATIONS	2	Front Wheel Alignment Check and Adjustment	4
SEALANTS	3	Ball Joint Dust Cover Check	6
SPECIAL TOOLS	3	SHOCK ABSORBER AND UPPER ARM	7
		LOWER ARM AND TORSION BAR	11
		STABILIZER BAR	15



33A-2 FRONT SUSPENSION – General Information/Service Specifications

GENERAL INFORMATION

33200010259

The front suspension is an independent suspension having the double wishbone combined with the torsion bar spring.

TORSION BAR

Items	Specifications
Length x O.D. mm	1,308 x 27

CONSTRUCTION DIAGRAM

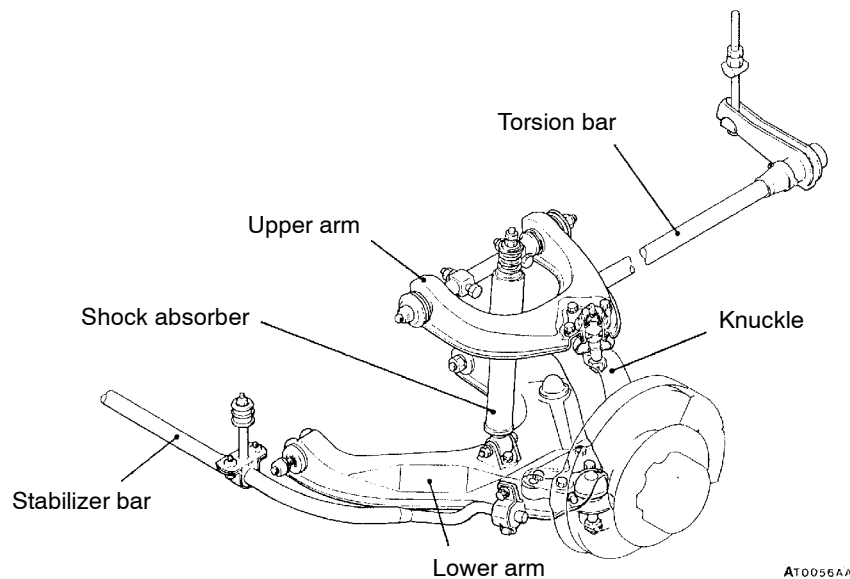

SERVICE SPECIFICATIONS

33200030156

Items	Standard value	Limit
Toe-in	At the centre of tyre thread mm	0 – 7
	Toe-angle (per wheel)	0° – 0°16'
Toe-out angle on turns (inner wheel when outer wheel at 20°)	21°18'	–
Camber	0°40' ± 30' (Difference between right and left within 30')	–
Caster	2°40' ± 1°00' (Difference between right and left within 30')	–
Kingpin angle	14°50'	–
Shock absorber attaching dimension mm	1 – 2	–
Upper arm ball joint starting torque Nm	0.8 – 3.4	–
Lower arm ball joint end play mm	–	0.3
Stabilizer link assembly attaching dimension mm	6 – 8	–

SEALANTS

33200050022

Item	Specified sealant
Upper ball joint dust cover to upper ball joint groove	3M ATD Part No.8661 or equivalent
Stopper bolt	3M Stud Locking Part No.4170 or equivalent

SPECIAL TOOLS

33200060148

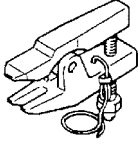
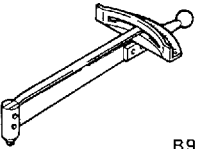
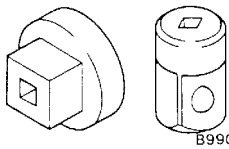
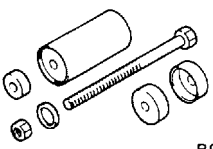
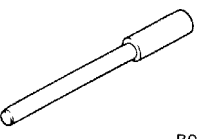
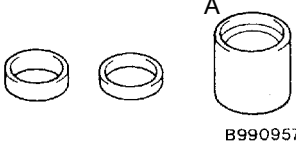
Tool	Number	Name	Use
 B991113	MB991113 or MB990635	Steering linkage puller	Upper or lower arm ball joint disconnection
 B990968	MB990968	Torque wrench	Upper arm ball joint rotation torque measurement
 B990326	MB990326	Preload socket	
 B991522	MB991522	Torsion bar bushing remover and installer	Lower arm bushing (A) removal and press-fitting
 B990883	MB990883	Rear suspension bushing arbor	Lower arm bushing (B) removal and press-fitting
 B990957	MB990957 A: MB990971	Lower arm bushing remover and installer A: Base	

ON-VEHICLE SERVICE

33100090274

FRONT WHEEL ALIGNMENT CHECK AND ADJUSTMENT

Measure the wheel alignment with the vehicle parked on a level surface.

The front suspension, steering system, and wheels should be serviced to normal condition prior to measurement of wheel alignment.

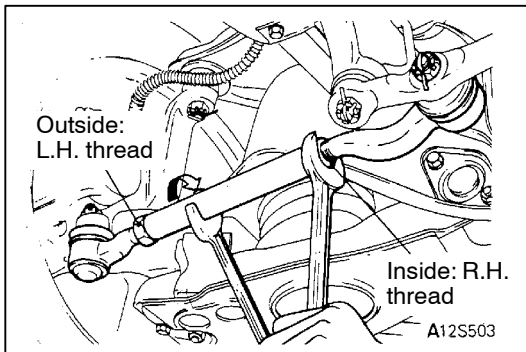
**TOE-IN****Standard value:**

At the centre of tyre tread 0 – 7 mm

Toe angle (per wheel) 0° – 0°16'

1. If the toe-in is not within the standard value, adjust the toe-in by turning the left and right tie rod turnbuckles by the same amount (in opposite directions).

Caution

- (1) **Take care when turning the tie rod end's outer side, as the threads are reversed.**
- (2) **Make sure that the left/right difference of the tie rod does not exceed 5 mm.**

NOTE

The toe will move out as the left turnbuckle is turned toward the front of the vehicle and the right turnbuckle is turned toward the rear of the vehicle.

2. Use a turning radius gauge to check that the steering angle is at the standard value. (Refer to GROUP 37A – On-vehicle Service.)

TOE-OUT ANGLE ON TURNS

To check the steering linkage, especially after the vehicle has been involved in an accident or if an accident is presumed, it is advisable to check the toe-out angle on turns in addition to the wheel alignment.

Conduct this test on the left turn as well as on the right turn.

Standard value:

21°18' (inner wheel when outer wheel at 20°)

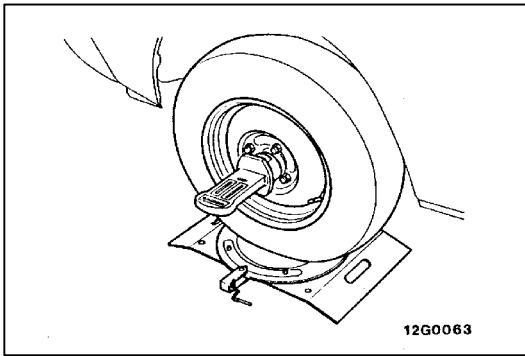

CAMBER AND CASTER

Standard value:

Camber $0^{\circ}40' \pm 30'$ (Difference between right and left within 30')

Caster $2^{\circ}40' \pm 1^{\circ}00'$ (Difference between right and left within 30')

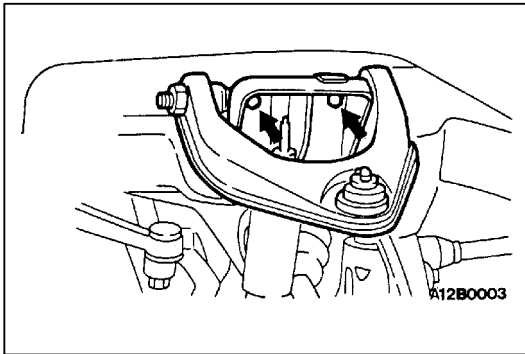

If the standard value is not obtained, make adjustment by the following procedure.

1. Loosen the upper arm mounting bolts and nuts.

NOTE

Remove the shock absorber mounting nut and lock nut, compress the shock absorber and loosen the upper arm mounting bolts and nuts.

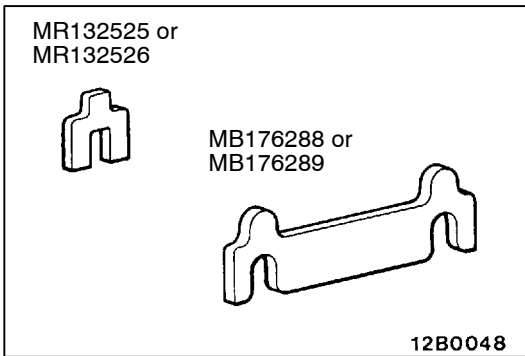

2. Increase or decrease shims between upper arm shaft and crossmember to adjust the camber and caster. (Refer to Charts for Shim Increase or Decrease.)

Caution

(1) Difference in shim thickness between front and rear must be 4 mm or less.

(2) Do not use 4 or more shims at one location.

Adjustment of shim	
Part number	Thickness mm
MR132525	1
MR132526	2
MB176288 (Front shim integral with rear shim)	1
MB176289 (Front shim integral with rear shim)	2

Charts for Shim Increase or Decrease

HOW TO USE CHARTS

These charts show how shims are added to or removed from existing shims.

EXAMPLE

To decrease camber by 30' and caster by 40', increase combined front side shim thickness by 3 mm and increase combined rear side shim thickness by 2 mm.

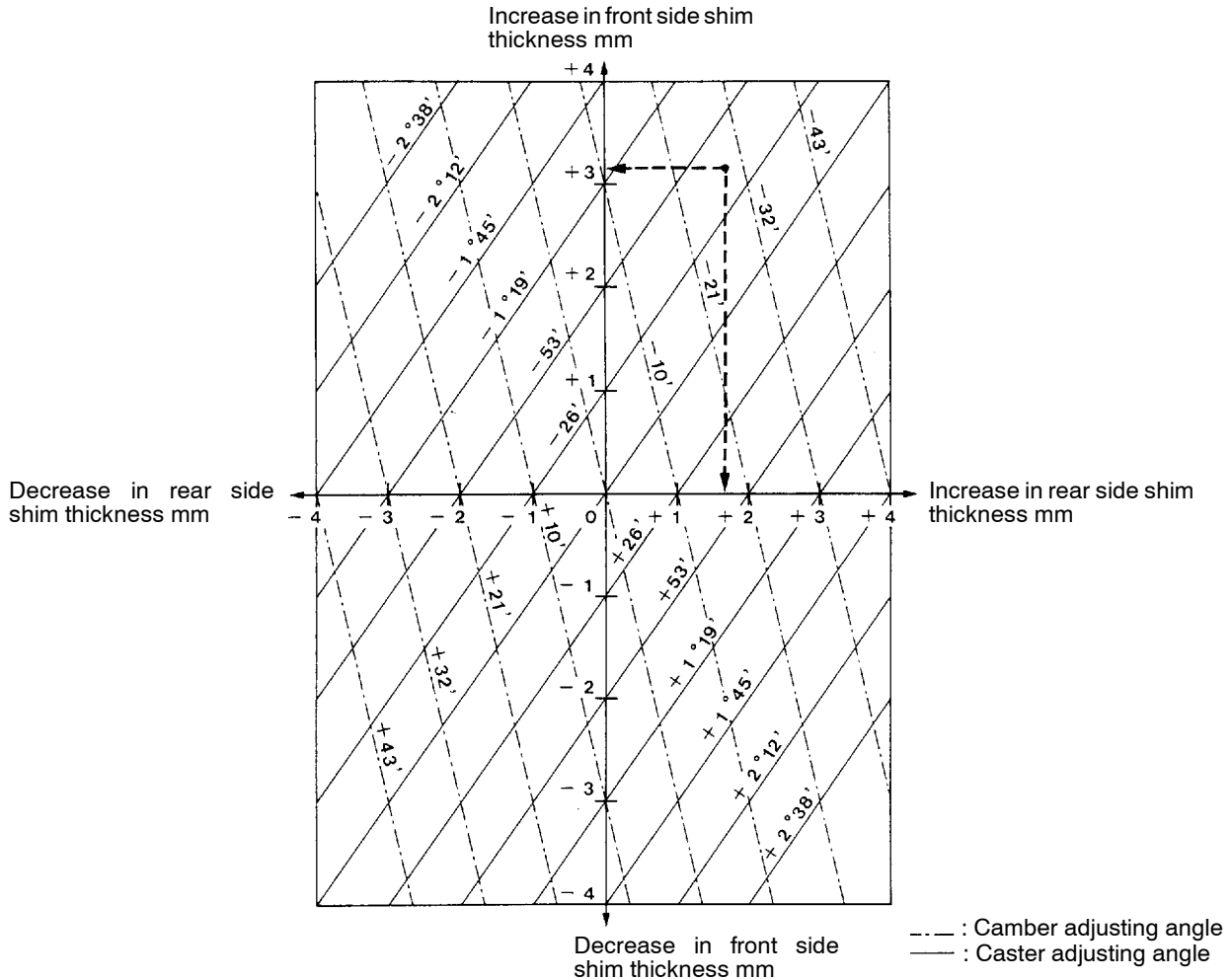

12V0034

KINGPIN INCLINATION

33200860106

Standard value: 14°50'

BALL JOINT DUST COVER CHECK

1. Check the dust cover for cracks or damage by pushing it with finger.
2. If the dust cover is cracked or damaged, replace lower arm ball joint assembly or upper arm ball joint assembly.

NOTE

Cracks or damage of the dust cover may cause damage of the ball joint.

SHOCK ABSORBER AND UPPER ARM

33200250118

REMOVAL AND INSTALLATION

Caution

*: Indicates parts which should be temporarily tightened, and then fully tightened with the vehicle on the ground in an unladen condition.

Pre-removal Operation

- Brake Fluid Draining

Post-installation Operation

- Press the dust cover with a finger to check whether the dust cover is cracked or damaged.
- Brake Fluid Supplying
- Brake Line Bleeding (Refer to GROUP 35A – On-vehicle Service.)
- Front Wheel Alignment Check and Adjustment (Refer to P.33A-4.)

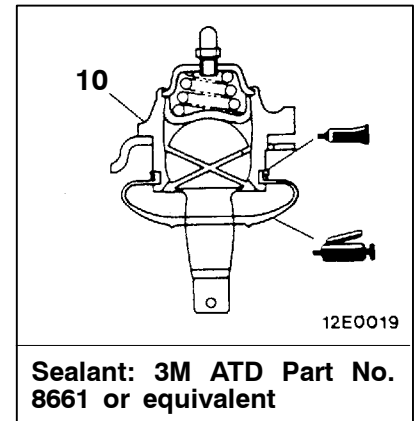
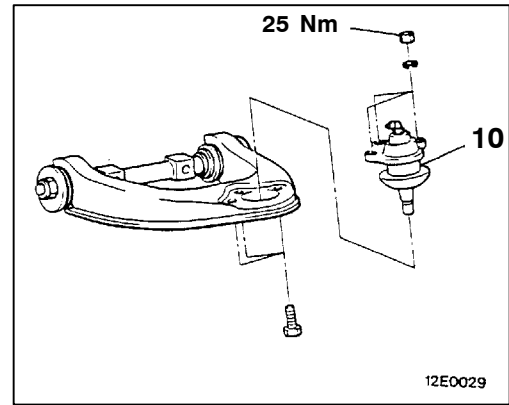
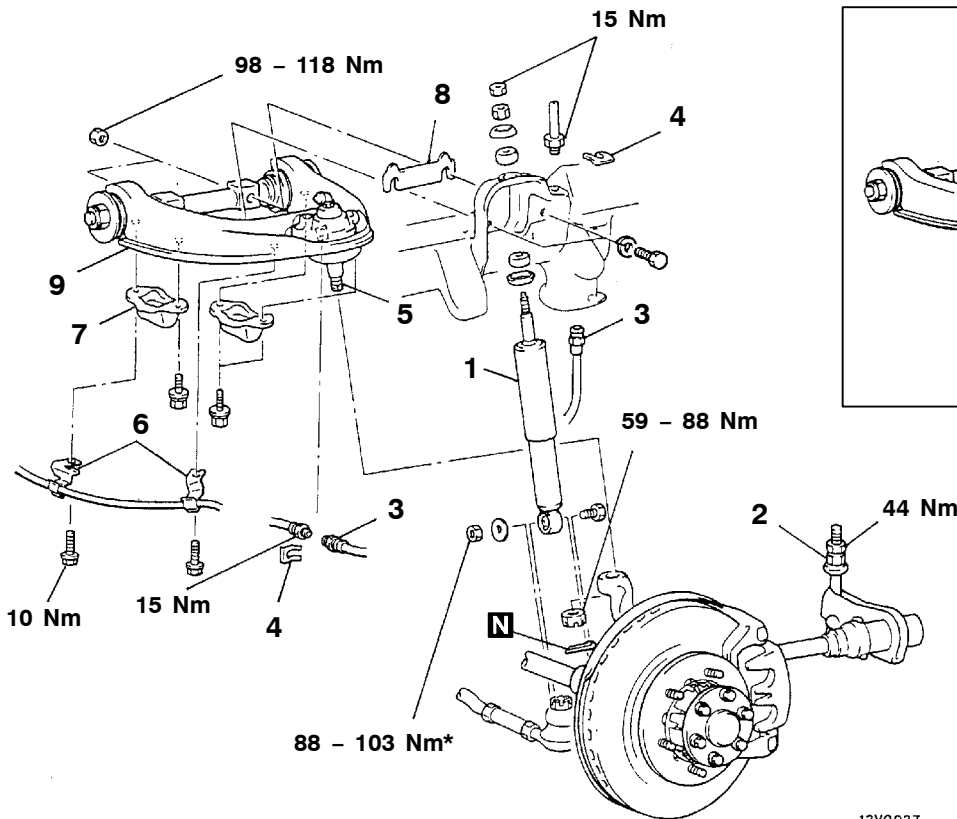

12V0027
00006196

Removal steps

- ▶D◀ 1. Shock absorber
- ▶C◀ • Bump stopper and bump stopper bracket clearance adjustment
- ◀A▶ 2. Rear anchor arm adjusting nut
- 3. Brake hose connection
- 4. Hose clip
- ◀B▶ 5. Upper arm ball joint connection

- 6. Speed sensor bracket <vehicles with ABS>
- ▶B◀ 7. Rebound stopper
- 8. Shims
- ▶A◀ 9. Upper arm
- 10. Upper arm ball joint assembly

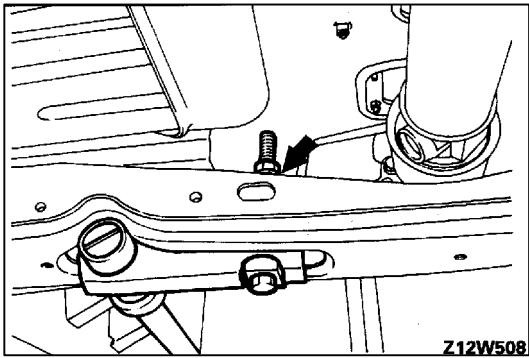

REMOVAL SERVICE POINTS

◀A▶ REAR ANCHOR ARM ADJUSTING NUT LOOSENING

Loosen the anchor arm bolt of the torsion bar all the way.

Caution

When the rear anchor arm adjusting nut is loosened, use a jack to support the lower arm of the side to be loosened.

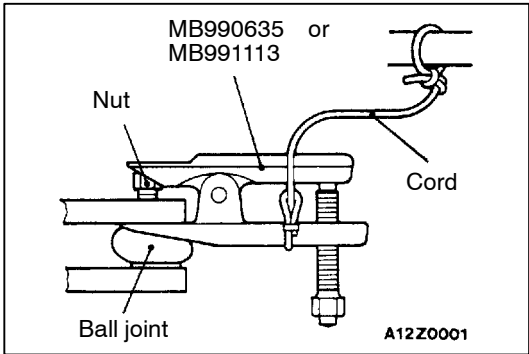

◀B▶ UPPER ARM BALL JOINT DISCONNECTION

Use special tools to disconnect the upper arm ball joint from the knuckle.

Caution

1. Support special tool with a cord, etc. to prevent it from coming off.
2. Only loosen the mounting nut, do not remove it from the ball joint.

◀C▶ SHIMS REMOVAL

NOTE

The camber and caster adjustment shims should be kept for use during assembly.

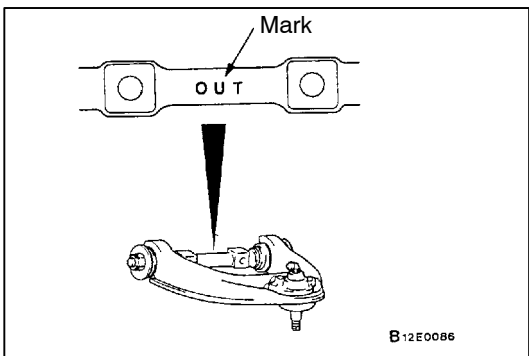

INSTALLATION SERVICE POINTS

▶A▶ UPPER ARM INSTALLATION

Install the upper arm so that the "OUT" mark on the upper arm shaft is facing toward the outside of the vehicle.

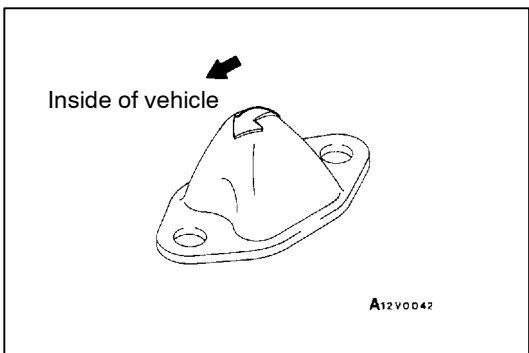

▶B▶ REBOUND STOPPER INSTALLATION

Install the rebound stopper so that its arrow faces inside of the vehicle.

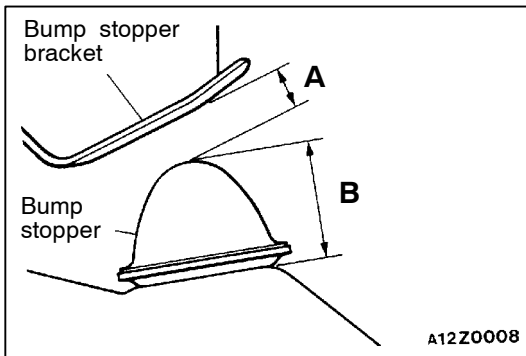

►C◄ **BUMP STOPPER AND BUMP STOPPER BRACKET CLEARANCE ADJUSTMENT**

1. With the vehicle in an unladen condition, dimension A from the bump stopper to the bump stopper bracket should be 18 mm.

NOTE

Dimension A will be (B = 50 mm) when the bump stopper is a new part. When the bump stopper is worn and becomes less than 50 mm, dimension A will increase by the decreased amount.

2. If dimension A is not 18 mm, adjust the rear anchor arm adjusting nut.

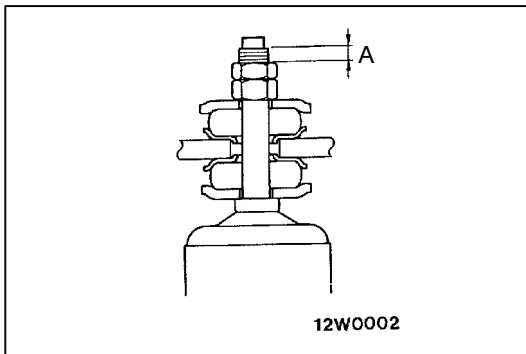

►D◄ **SHOCK ABSORBER INSTALLATION**

Install the shock absorber so that the distance (A) shown in the illustration is at the standard value.

Standard value (A): 1 – 2 mm

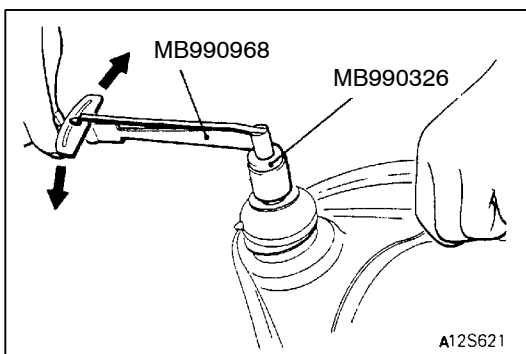

INSPECTION

33200260074

UPPER ARM BALL JOINT BREAKAWAY TORQUE CHECK

1. After shaking the upper arm ball joint assembly stud several times, install the nut to the stud and use the special tool to measure the breakaway torque of the upper arm ball joint assembly.

Standard value: 0.8 – 3.4 Nm

2. When the measured value exceeds the standard value, replace the upper arm ball joint.
3. When the measured value is lower than the standard value, check that the ball joint turns smoothly without excessive play. If not, it is possible to use that upper arm ball joint.

UPPER ARM BALL JOINT DUST COVER CHECK

1. Press the dust cover with a finger to check whether the dust cover is cracked or damaged.
2. If dust cover is cracked or damaged, replace the upper arm ball joint. Cracked or damaged dust cover may cause damage to the ball joint. In addition, if the dust cover is damaged during service work, replace the dust cover.

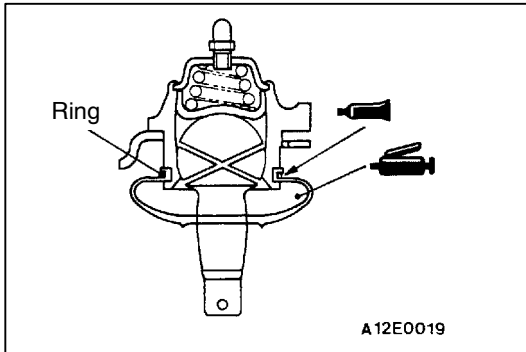
**UPPER ARM BALL JOINT DUST COVER REPLACEMENT**

33200800092

Only when dust cover is damaged accidentally during service work, replace the dust cover as follows:

1. Apply multipurpose grease to the interior of the dust cover and the upper arm ball joint.
2. Apply the specified sealant to the ball joint groove and secure the dust cover to the upper arm ball joint with ring.

Specified sealant:**3M ATD Part No. 8661 or equivalent**

3. Press the dust cover with a finger to check whether the dust cover is cracked or damaged.

LOWER ARM AND TORSION BAR

33200280117

REMOVAL AND INSTALLATION

Caution

*: Indicates parts which should be temporarily tightened, and then fully tightened with the vehicle on the ground in an unladen condition.

Pre-removal Operation

- Under Cover and Skid Plate Removal

Post-installation Operation

- Press the dust cover with a finger to check whether the dust cover is cracked or damaged.
- Front Wheel Alignment Check and Adjustment (Refer to P.33A-4.)
- Under Cover and Skid Plate Installation

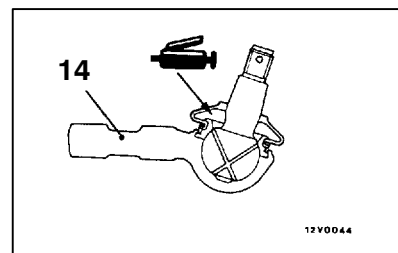
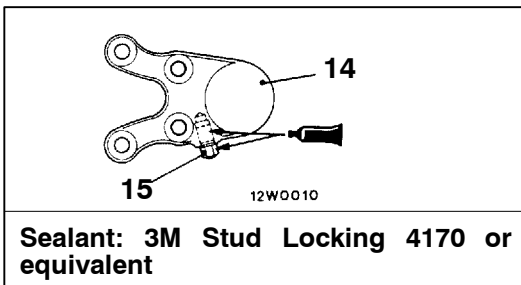
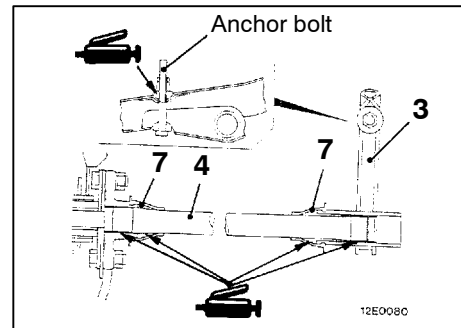
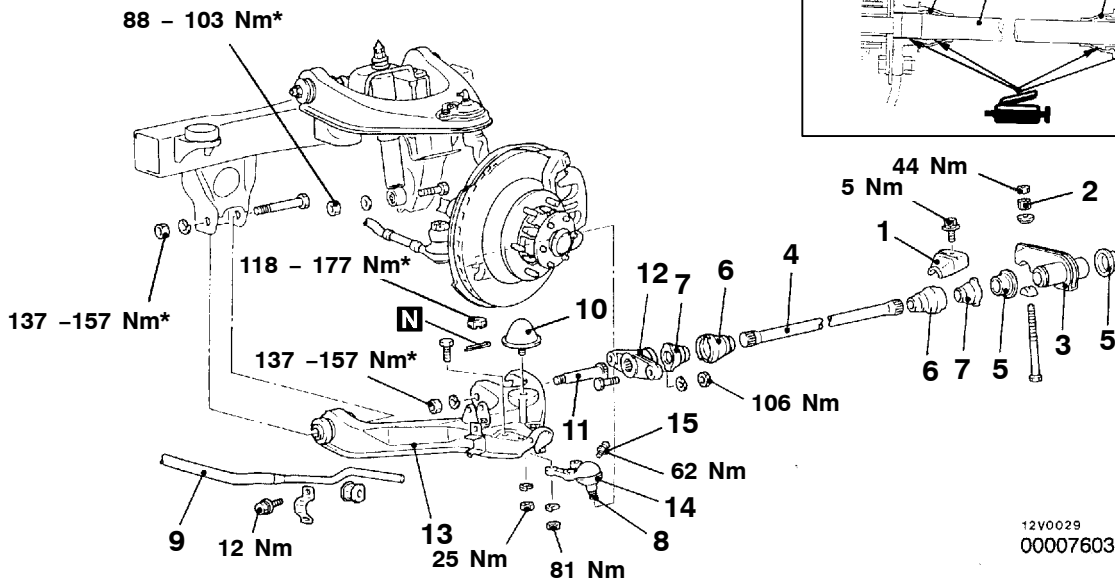

Removal steps

- ▶B◀ • Bump stopper and bump stopper bracket clearance adjustment
- 1. Heat protector (right side only)
- ▶A◀ 2. Anchor arm assembly adjusting nut
- ▶A◀ 3. Rear anchor arm assembly
- ▶A◀ 4. Torsion bar
- 5. Anchor collar
- 6. Heat cover (right side only)
- 7. Dust covers
- ▶A◀ 8. Lower arm ball joint connection
- 9. Stabilizer bar connection
- 10. Bump stopper
- ▶A◀ 11. Lower arm shaft
- ▶A◀ 12. Front anchor arm
- ▶A◀ 13. Lower arm
- ▶A◀ 14. Lower arm ball joint assembly
- ▶A◀ 15. Stopper bolt

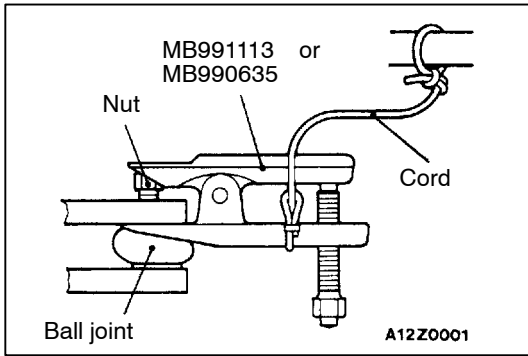

REMOVAL SERVICE POINT

◀A▶ LOWER ARM BALL JOINT DISCONNECTION

Use special tools to disconnect the lower arm ball joint from the knuckle.

Caution

1. Support special tool with a cord, etc. to prevent it from coming off.
2. Only loosen the mounting nut, do not remove it from the ball joint.

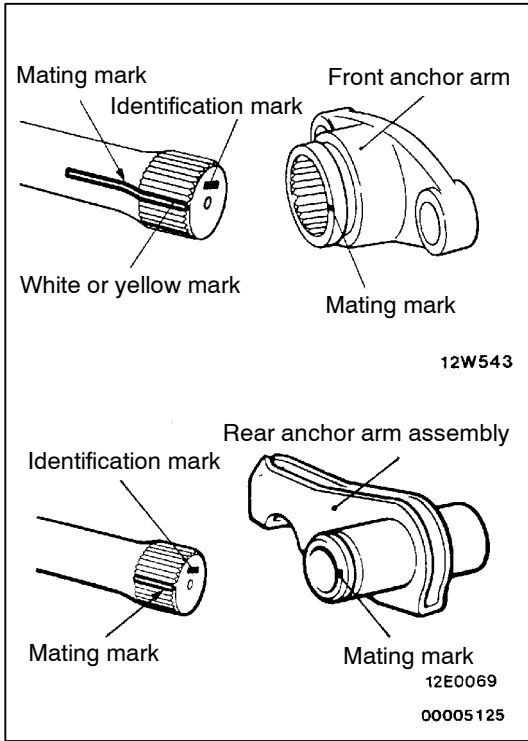

INSTALLATION SERVICE POINTS

▶A◀ FRONT ANCHOR ARM/TORSION BAR/REAR ANCHOR ARM INSTALLATION

1. Check the identification marks at the end of the left and right torsion bars.
 R → for right side
 L → for left side
2. When installing the torsion bar, align the white mark on the serrated section of the torsion bar with the mating mark on the anchor arm.

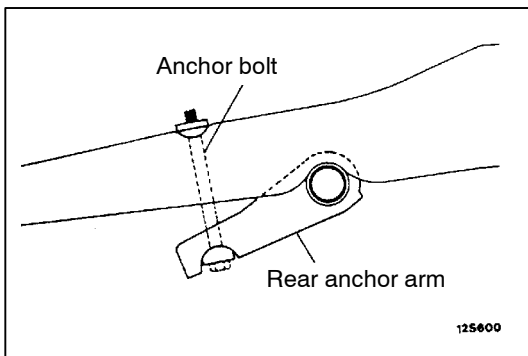

3. Mount the anchor bolt as shown in the illustration, and install the rear anchor arm adjusting nut.

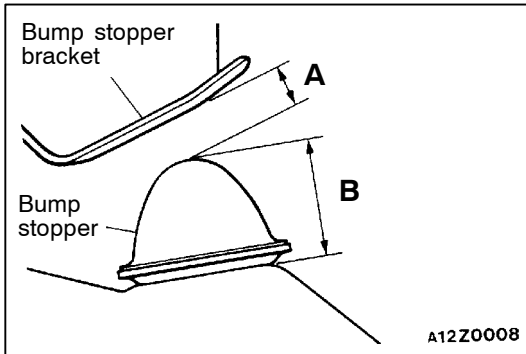

►B◄ BUMP STOPPER AND BUMP STOPPER BRACKET CLEARANCE ADJUSTMENT

1. With the vehicle in an unladen condition, dimension A from the bump stopper to the bump stopper bracket should be 18 mm.

NOTE

Dimension A will be 18 mm (B = 50 mm) when the bump stopper is a new part. When the bump stopper is worn and becomes less than 50 mm, dimension A will increase by the decreased amount.

2. If dimension A is not 18 mm, adjust the anchor arm assembly adjusting nut.

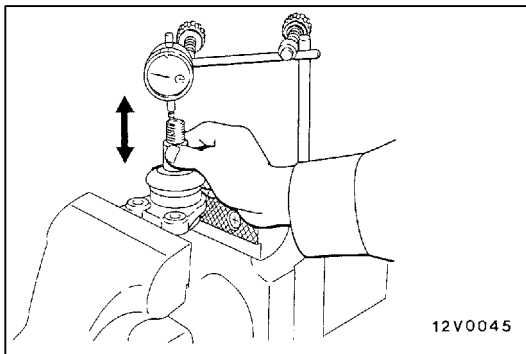

INSPECTION

33200290080

LOWER ARM BALL JOINT END PLAY

Check the lower arm ball joint assembly end play by following the steps below.

1. Measure the lower arm ball joint assembly end play with a dial indicator.

Limit: 0.3 mm

2. If the lower arm ball joint assembly end play exceeds the limit, replace the lower arm ball joint assembly.

LOWER ARM BALL JOINT DUST COVER CHECK

1. Press the dust cover with a finger to check whether the dust cover is cracked or damaged.
2. When dust cover is cracked or damaged, replace the lower arm ball joint assembly.

NOTE

If the dust cover is cracked, the ball joint could be damaged, so if the dust cover is damaged during maintenance work, replace it.

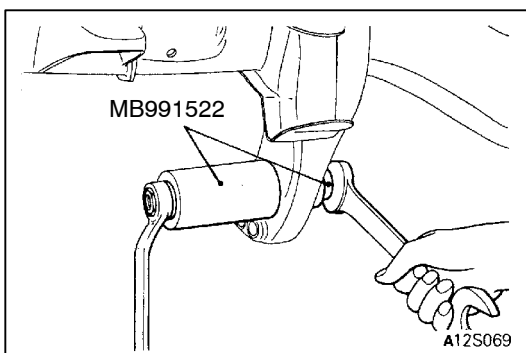

REAR LOWER ARM BUSHING REPLACEMENT

33200810149

1. Using the special tool, remove the lower arm bushing (A) from the bracket.

NOTE

When removing the left hand rear lower arm bushing, detach the differential carrier. (Refer to GROUP 26 – Differential carrier.)

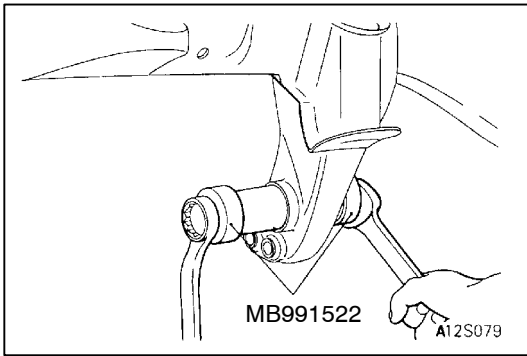

- Using the special tool, press-fit the lower arm bushing (A) into the bracket.

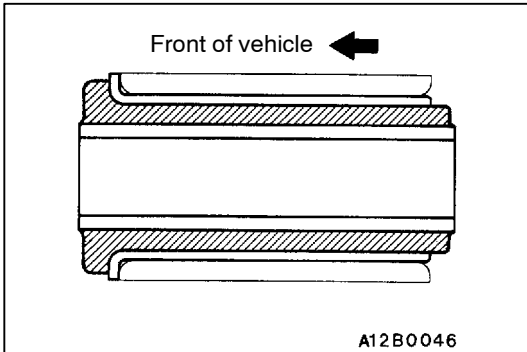

NOTE
Install the rear lower arm bushing in the direction shown in the illustration.

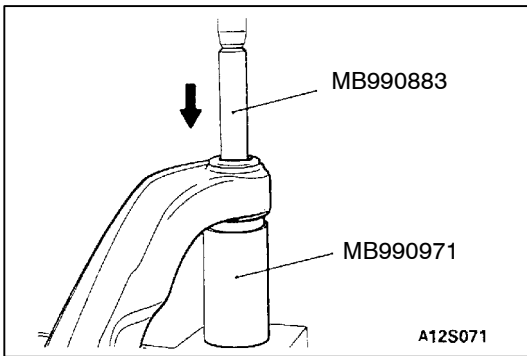

FRONT LOWER ARM BUSHING REPLACEMENT

33200810156

- Remove the front lower arm bushing from the lower arm by using special tools.

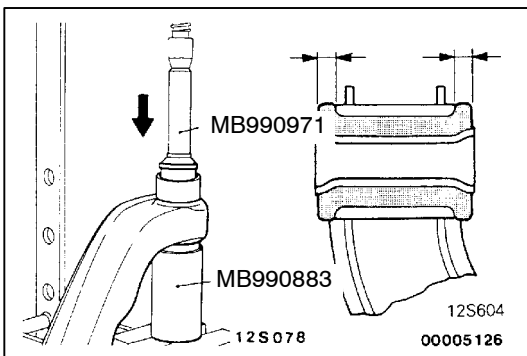

- Coat the front lower arm bushing and the lower arm with soap solution and press-fit the front lower arm bushing into the lower arm by using special tools and taking care not to twist or tilt the front lower arm bushing.

NOTE
Press-fit the front lower arm bushing again from the opposite side to equalize bushing projections at both ends.

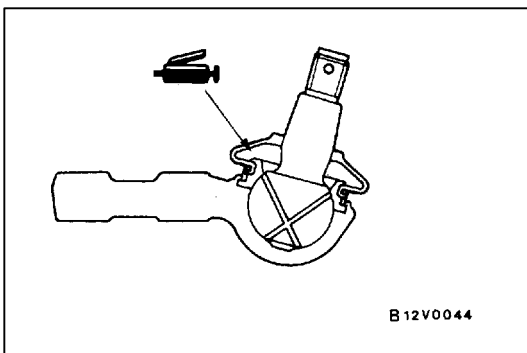

LOWER ARM BALL JOINT DUST COVER REPLACEMENT

33200820104

Only when dust cover is damaged accidentally during service work, replace the dust cover as follows:

- Apply multipurpose grease to the interior of the dust cover and the lower arm ball joint.
- Secure the dust cover to the lower arm ball joint with ring.
- Press the dust cover with a finger to check whether the dust cover is cracked or damaged.

STABILIZER BAR

33200400063

REMOVAL AND INSTALLATION

Pre-removal and Post-installation Operation

- Under Cover and Skid Plate Removal and Installation

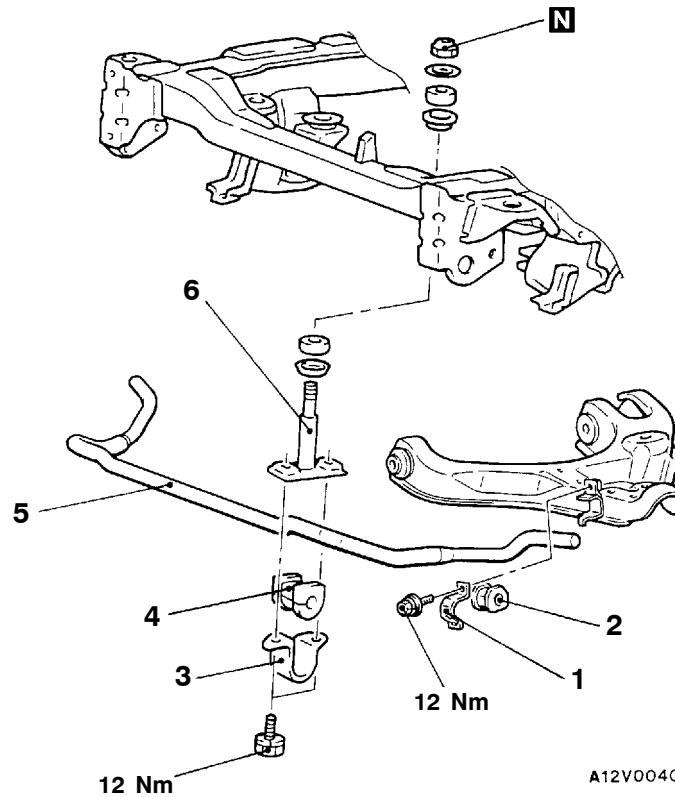

A12V0040

Removal steps

- ▶A◀ • Stabilizer link assembly mounting nut adjustment
- 1. Stabilizer bracket (A)
- 2. Bushing

- 3. Stabilizer bracket
- 4. Bushing
- 5. Stabilizer bar
- 6. Stabilizer link assembly

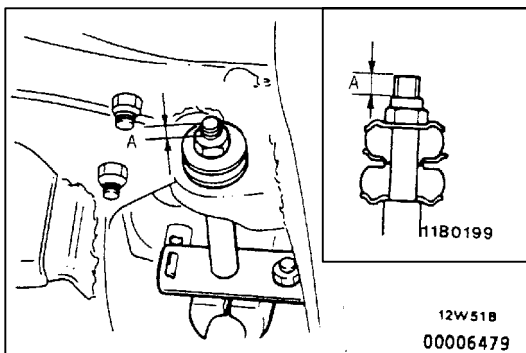

12W51B
00006479

INSTALLATION SERVICE POINT

▶A◀ **STABILIZER LINK ASSEMBLY MOUNTING NUT ADJUSTMENT**

Tighten the nut so that the dimension A shown in the figure is at the standard value.

Standard value (A): 6 – 8 mm

NOTES